

IPP-ITX Series

IPP-ITX Series Panel PC provide an industrial-grade, touch display with front IP65 waterproof designed, multi-serial ports support. Its plug-and-play integrated into Automation, Industry embedded applications

Features

- Industrial Panel PC with 35/65W Performance
- Industrial-grade Panel
- Front IP65 Water & Dust Proof
- PCAP multi touch screen
- Supports extended display configuration by multiple interface
- Supports certified mini-ITX motherboards (up to 65W TDP processor)



Specifications

		IPP-H610-156W	IPP-H610-215W
Touch Display Panel VCCI	Screen	15.6 inch	21.5 inch
	Active Display Area	344.16 x 193.59 mm	475 x 267 mm
	Resolution	1920x1080	1920x1080
	Screen Ratio		16:9
	LCD Brightness	300 nits	450 nits
	Contrast Ratio	800:1	1000:1
	Surface Hardness		>7H
	Touch surface treatment		AH
	Touch Screen		P-CAP,10 Touch Point,multi-touch with finger
System	CPU	LGA1700 for Intel® 13 th / 12 th Gen. Core™ i9/ i7/ i5/ i3/ Pentium®/ Celeron® Processors. Max. 65W TDP Intel® H610 Chipset	
	Memory	2 x SO-DIMM DDR4(Max. 64GB)	
	Storage	1 x M.2 M key, Type 2242/ 2260/ 2280 (PCIe x4/ SATA mode)	
	Expansion Slot	1 x M.2 E key, Type 2230 for WIFI/ BT device (PCIe & CNVi)	
	Operating System	Windows 10 IoT Enterprise 2021 LTSC, Ubuntu, Yocto	
I/O	Display Port	1	
	HDMI	2	
	USB 3.2 Gen1	4	
	Ethernet	2 x RJ45	
	Serial Port	6 COM (2 x RS232/ 422/ 485, 4 x RS232)	
	Audio jack	2	
	PCIe bracket	2 x PCIe slot	
	PSU	1 on chassis	
	Power Switch	1	
Power Input	Power Supply	1 x 350W	
Physical Characteristics	Enclosure	Chassis with active fan	
	Mounting	Panel mount, VESA Mount, Wall Mount	
	Weight	TBD	
	Dimensions	387.4(H)x236.8(V)x60(D) mm	419 x 269 x 108.2 mm (W x H x D)
Environment	Operating Temperature	0~50°C	
	Storage Temperature	-30~60°C	
	Relative Humidity	10 ~ 90%, non-condensing	
Certification	EMC	CE, FCC,VCCI	
	Safety	CE, BSMI	

Specifications

		IPP-Q670-156W	IPP-Q670-215W
Touch Display Panel	Screen	15.6 inch	21.5 inch
	Active Display Area	344.16 x 193.59 mm	475 x 267 mm
	Resolution	1920x1080	1920x1080
	Screen Ratio		16:9
	LCD Brightness	300 nits	450 nits
	Contrast Ratio	800:1	1000:1
	Surface Hardness		>7H
	Touch surface treatment		AH
	Touch Screen		P-CAP, 10 Touch Point
System	CPU	LGA1700 for Intel® 13 th / 12 th Gen. Core™ i9/ i7/ i5/ i3/ Pentium®/ Celeron® Processors. Max. 65W TDP Intel® Q670E Chipset	
	Memory	2 x SO-DIMM DDR5 (Max. 64GB)	
	Storage	1 x M.2 M key, Type 2242/ 2260/ 2280 (PCIe x4/ SATA mode)	
	Expansion Slot	1 x M.2 E key, Type 2230 for WIFI/ BT device (PCIe & CNVi)	
	Operating System	Windows 10 IoT Enterprise 2021 LTSC, Ubuntu, Yocto	
I/O	Display Port	3	
	HDMI	1	
	USB 3.2 Gen2/ Gen1	3 (2*Type A+ 1*Type C)/1 (Type A)	
	USB 2.0	4 (Type A)	
	Ethernet	1 x Intel® I210at(1G), 1 x Intel® I225LM (2.5G) (Intel vPro supported)	
	Serial Port	5 COM (2 x RS232/ 422/ 485, 3 x RS232)	
	Audio jack	2	
	PCIe bracket	2 x PCIe slot	
	PS2	1 x Keyboard, 1x Mouse	
	Power Switch	1	
Power Input	Power Supply	1 x 350W	
Physical Characteristics	Enclosure	Chassis with active fan	
	Mounting	Panel mount, VESA Mount, Wall Mount	
	Weight	TBD	
	Dimensions	387.4(H)x236.8(V)x60(D) mm	558 x 349.8 x 108.2 mm(W x H x D)
Environment	Operating Temperature	0~50°C	
	Storage Temperature	-30~60°C	
	Relative Humidity	10 ~ 90%, non-condensing	
Certification	EMC	CE, FCC, VCCI	
	Safety	CE, BSMI	

Dimension (15.6")

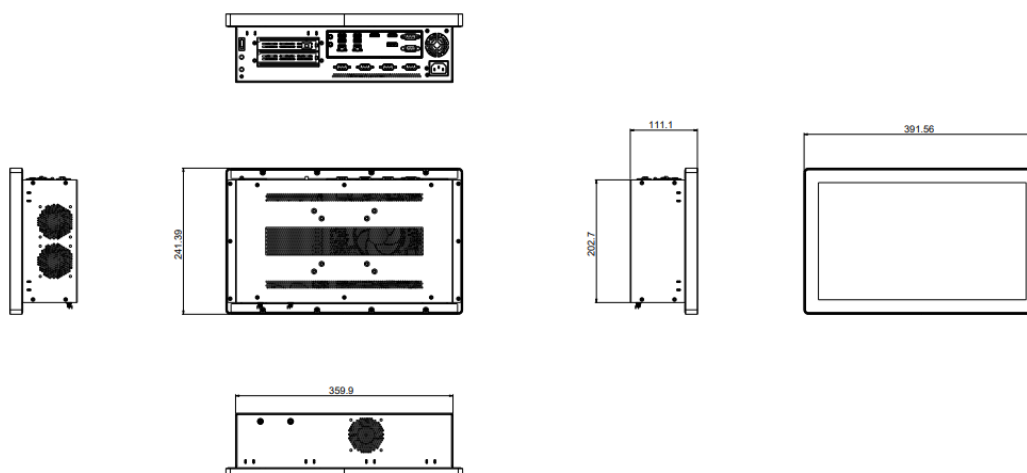

Dimension (21.5")

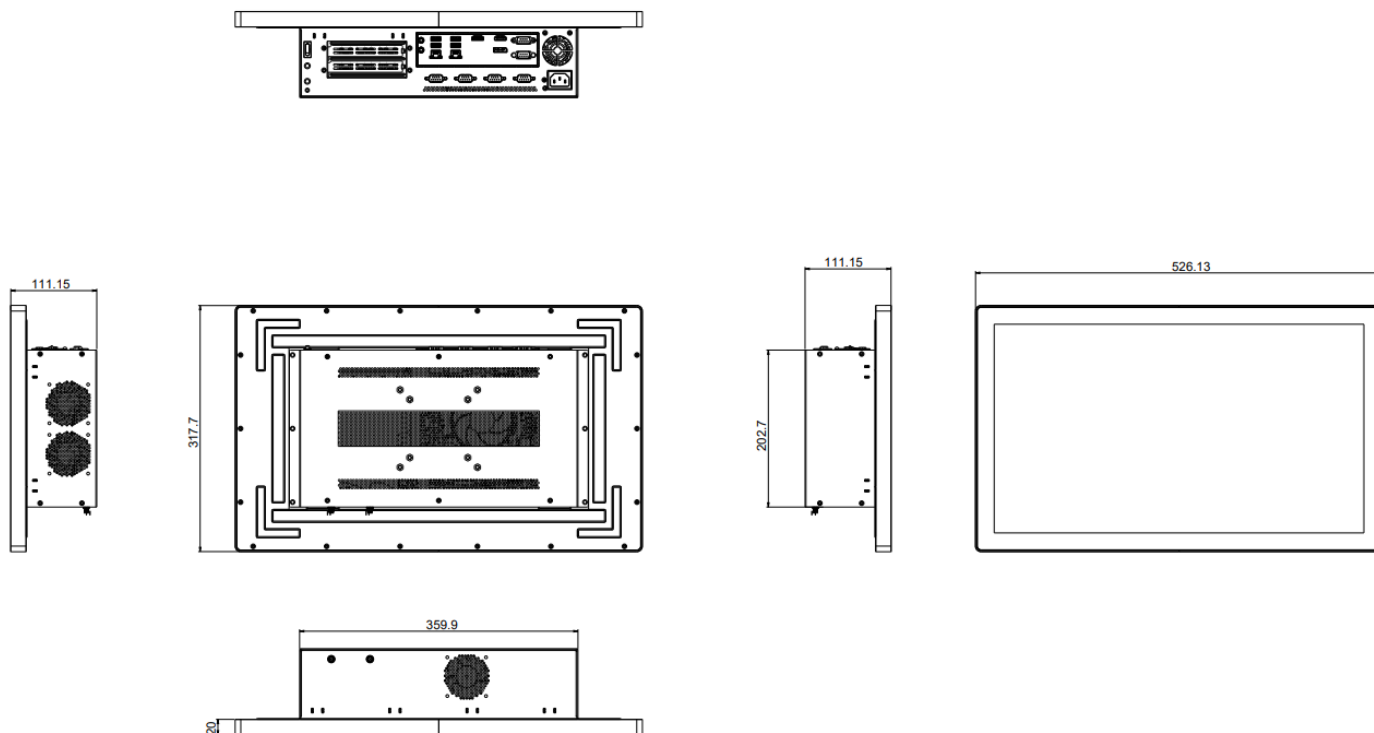

Order Information

Model name	Part number	Description
IPP-H610-156W	TBD	15.6 Inch Open Frame Touch PC with chipset H610
IPP-H610-215W	TBD	21.5 Inch Open Frame Touch PC with chipset H610
IPP-Q670E-156W	TBD	15.6 Inch Open Frame Touch PC with chipset Q670
IPP-Q670E-215W	TBD	21.5 Inch Open Frame Touch PC with chipset Q670
Power Adapter 65W	TBD	ADP 65W 19V C6 90D 5.5P B//DELTA/ADP-65DE BK REV:01
Mounting kits	TBD	Panel Mount Kit